

T1/E1-over-IP Gateway

TC3845

- **Transports 4 Ch. T1/E1 Over Ethernet/IP**
- **Near Stratum-II Clock Precision & Extremely Low Latency**
- **Point-to-Point & Point-to-MultiPoint Applications**
- **VLAN and QoS Support**
- **Manage Via Web, SNMP, Serial Console, Telnet**
- **Temperature & Power Consumption Monitoring**
- **Extreme Temp (-40°C to +80°C) Optional**
- **Meets or Exceeds IEC 61850-3, IEEE1613 & NEMA TS-2 Standards**
- **Member of the JumboSwitch® Product Family**



TC3845 - T1/E1-over-IP Gateway

Featuring extremely low latency, the TC3845 T1/E1-over-IP Gateway transports T1/E1 over Ethernet/IP networks. It is simple to configure and supports both point-to-point and point-to-multi point topologies.

A High-precision near Stratum II reference clock (OCXO) is used for optimal jitter and wander performance that complies with the ITU-T G.823 and G.824 standards. Using an OCXO also allows the unit to handle large temperature swings without any bit errors or loss of sync that would otherwise be present when using a less stable clock source.

Four channels of T1, E1, or combinations are transparently extended over Layer 2/3 IP Networks. The TC3845 achieves minimal end-to-end processing delay by using high-performance adaptive clock recovery buffering and forwarding technology. For reliable communications, the TC3845 supports VLAN and QoS for packet prioritization.

Key features include Traffic Monitoring and Statistics, Network Time Server (NTS), Remote Firmware Upgrade and Temperature and Power Consumption Monitoring.

Setup, diagnostics, and management are accessed via Web, SNMP, Serial Console, and Telnet. Diagnostics include LED indicators and local and remote loopback to assist with troubleshooting and maintenance.

Each T1/E1 channel is independent and transparent to protocols and signaling that run over T1/E1. The TC3845 supports all applicable standards and line codes.

The TC3845 interface card can fit into any available JumboSwitch housing options including 1S/2S Standalone chassis and 2U/4U card cages. Power supply options are 12VDC, 24VDC, -48VDC or 115/230VAC. Standard operating temperature is -20°C to +70°C and the extreme temperature version is -40°C to +80°C.

Applications

Typical applications include transporting voice, video, and data across IP networks.

For example, the TC3845 is used to extend T1/E1 links between PBX's, connect video conferencing, or link Cell Towers to Central Offices, all over existing Layer 2 / Layer 3 Networks.

Environmental & EMI Compliance

The JumboSwitch and its product family interface cards meet or exceed all pertinent industrial environmental and EMI industry standards including IEC 61850-3 and IEEE 1613 for networking devices installed in electric power substations and NEMA TS-2 for traffic control environments. The chart below details information related to specific JumboSwitch environmental and EMI compliance testing.

TC Communications Industrial grade products are manufactured with special components, connectors and circuitry. This ensures reliable operation in the event of wide temperature swings, electromagnetic interference (EMI), radio interference, vibrations, or moisture and humidity fluctuations. Conformal coating is optional

	Tests	Industrial Standards	TC Communications - JumboSwitch Type Test and Levels	
			Power Supply Unit (PSU)	RJ-45 & Signal
Temperature/Humidity	Low Temperature Use	IEC 61850-3, IEEE 1613, NEMA TS-2	IEC 60068-2-1; Ae; -40°C; 16 hour	
	Low Temperature Storage	IEC 61850-3, IEEE 1613, NEMA TS-2		
	High Temperature Use	IEC 61850-3, IEEE 1613, NEMA TS-2	IEC 60068-2-2; Be; +80°C; 16 hour	
	High Temperature Storage	IEC 61850-3, IEEE 1613, NEMA TS-2	IEC 60068-2-2; Bd; +85°C; 16 hour	
	Damp Heat	IEC 61850-3, IEEE 1613, NEMA TS-2	IEC 60068-2-30; Db; +55°C; 95%; 96 hours	
Mechanical	Vibration	IEC 61850-3, IEEE 1613, NEMA TS-2	IEC 60068-2-6; Fc; 3 - 150 Hz; 7.5 mm; 2 g; 10 sweeps per axis	
	Shock	IEC 61850-3, IEEE 1613, NEMA TS-2	IEC 60068-2-27; Ea; 30g; 11ms	
ElectroMagnetic Compatibility	Electrostatic Discharge Immunity	IEEE 1613	IEC 61000-4-2; 8kV contact; 15 kV air	
	Radiated RF Immunity	IEC 61850-3, IEEE 1613	IEC 61000-4-3; 80 MHz - 1000 MHz; 20 V/m; AM 80% 1 kHz	
	EFT/Burst Immunity	IEC 61850-3, IEEE 1613	IEC 61000-4-4; 4 kV CM	IEC 61000-4-4; 4 kV CM
	Surge Immunity	IEC 61850-3	IEC 61000-4-5; 4 kV LG; 2 kV LL	IEC 61000-4-5; 4 kV LG; 2 kV LL
	Conducted RF immunity	IEC 61850-3	IEC 61000-4-6; 150 kHz - 80 MHz; 10 V; AM 80% 1 kHz	IEC 61000-4-6; 150 kHz - 80 MHz; 10 V; AM 80% 1 kHz
	Magnetic Field Immunity	IEC 61850-3	IEC 61000-4-8; 50 Hz; 100 A/m cont.; 1000 A/m 1 s	
	Damped Oscillatory Magnetic Field Immunity	IEC 61850-3	IEC 61000-4-10; 100 kHz; 30 A/m	
	Damped Oscillatory Magnetic Field Immunity	IEC 61850-3	IEC 61000-4-10; 1 MHz; 30 A/m	
Power Supply Unit (PSU) Variations	AC Voltage Dips	IEC 61850-3	IEC 61000-4-11; 30% & 100%, 0.5s	NA
	DC Voltage Dips	IEC 61850-3	IEC 61000-4-29; 40% & 70%, 0.1s	NA
	Damped Oscillatory Wave	IEC 61850-3	IEC 61000-4-12; 2.5 kV CM, 1.0 kV DM @1MHz	IEC 61000-4-12; 2.5 kV CM, 1.0 kV DM @ 1MHz
	Conducted PF CM Voltage	IEC 61850-3	IEC 61000-4-16; 50 Hz; 30 V cont.; 300 V 1s	IEC 61000-4-16; 50 Hz; 30 V cont.; 300 V 1s
	Conducted Emission	IEC 61850-3	CE/FCC/CISPR22 class A	CE/FCC/CISPR22 class A
	Conducted emission	IEC 61850-3	CE/FCC/CISPR22 class A	CE/FCC/CISPR22 class A
	Radiated emission	IEC 61850-3	CE/FCC/CISPR22 class A	
Dielectric	Dielectric 50 Hz Test	IEEE 1613	IEC 60255-5; 2 kV	IEC 60255-5; 0.5 kV
	Impulse Voltage Test	IEEE 1613	IEC60255-5; 5 kV	IEC 60255-5; 5 kV

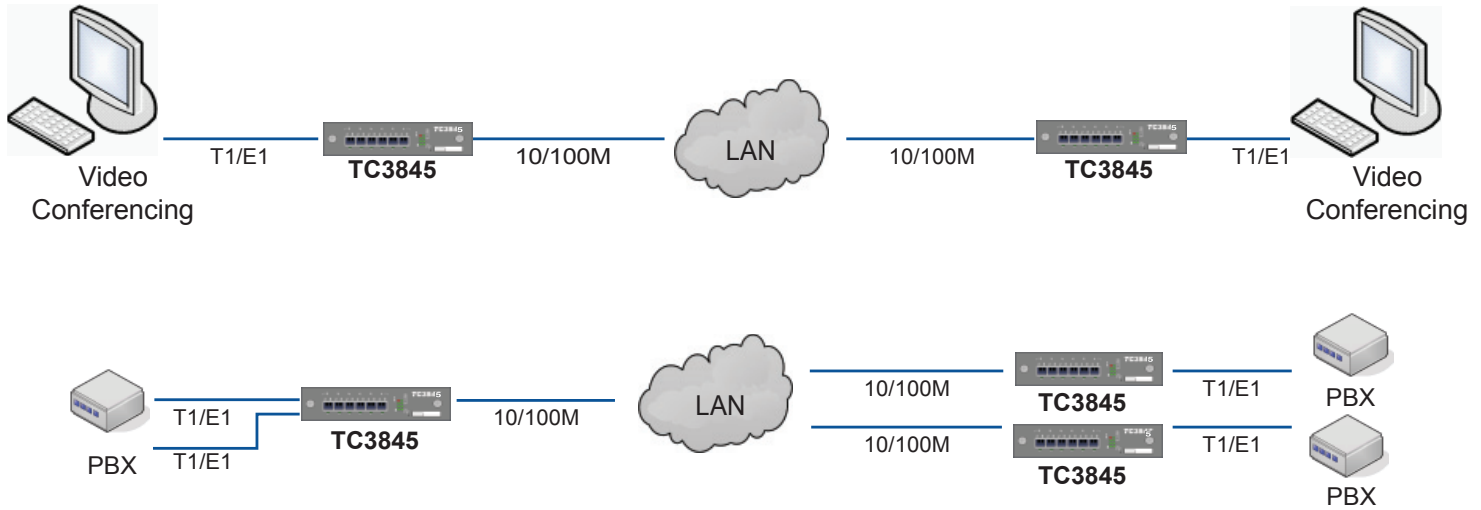

Typical Point-to-Point and Multi-Point Applications Using TC3845S to Extend T1/E1 Through an Existing Local Area Network

Data Rates

- T11.544 Mbps
- E12.048 Mbps
- Ethernet10/100 Mbps Full Duplex
- Console9.6K

Connection Capacity

- T1/E14 Channels
- Ethernet1 Port

Electrical

- T1 Interface
 - Line CodeAMI, B8ZS
 - Standards...AT&T TR-62411, G.703
 -G.704, G.824, ANSI T1.403
 - ConnectorRJ48
 - Impedance.....100 Ohm
- E1 Interface
 - Line Code.....AMI, HDB3
 - Standards.....G.703, G.704, G.706
 -G.732, G.823
 - Connector.....RJ48, BNC via cable
 - Impedance.....75, 120 Ohm
- Ethernet Interface
 - StandardsIEEE 802.3,
 -802.3u, 802.1p&Q
 - Connector.....RJ45
 - Console Port.....RJ45

System

- Bit Error Rate1 in 10¹⁰ or Better

Note - Information contained in this data sheet is subject to change without prior notice. 010A

Diagnostic Functions

- Local and Remote Loopback for T1/E1 and Ethernet

LEDs

- Unit Status.....PWR (A, B), Alarm
-Vcc, CS, MS
- T1/E1..... Status
- Ethernet.....Link/Act

Power

- Standard.....12VDC
- Optional.....24, -48 VDC
-90-260 VAC, 50/60Hz
- Power Consumption.....<10W

Operating Temperature

- High Temp-20°C to 70°C
- Extreme Temp-40°C to 80°C

Storage

- Temperature.....-40°C to 90°C
- Humidity.....95% non-condensing

Physical (Standalone Unit)

- Height.....(3.89 cm) 1.53"
- Width.....(18.54 cm) 7.3"
- Depth.....(24.87 cm) 9.79"
- Weight.....(0.4 kg) 1.0 lbs



#1045959

TC Communications, Inc.
 17881 Cartwright Road
 Irvine, CA 92614 U.S.A.
 Factory Tel: (949) 852-1972
 Fax: (949) 852-1948

Sales Office
 U.S.A. Domestic International:
 (800) 569-4736 (949) 852-1973

Web Site: www.tccomm.com
 E-mail: sales@tccomm.com

